



NEWSLETTER OF THE LOUISIANA ARCHAEOLOGICAL SOCIETY

Spring 2009

Vol. 36, No. 3

Joe Saunders, Thurman Allen and others coring one of the LSU Campus Mounds in Baton Rouge April 15, 2009. Photo by Bill Feig, Baton Rouge Morning Advocate.
See page 9.



LAS Newsletter printed
courtesy of
R. Christopher Goodwin
and Associates, Inc.
New Orleans, LA

Check Inside for:

Report on the LAS/MAA 2009 meeting.....	2
LAS Chapter and Membership News.....	3
Site Preservation News.....	6
The State of Archaeology in LA.....	7
Coring the LSU Campus Mounds.....	9
Outreach archaeology in Kisatchie National Forest.....	11
Regional Archaeology Reports.....	12
Official LAS and other Archaeology Business.....	21
Conferences, Meetings, Exhibits, Websites, Etc... ..	26
Advice on how archaeologists can get rich and be better looking.....	29

2009 LAS/MAA meeting, Eola Hotel, Natchez, MS, Feb. 27, 28 and March 1.

Below are scenes from the first ever joint meeting of the archaeological groups of Louisiana and Mississippi. The audience at presentations on Friday and Saturday sessions took in information on historic and prehistoric sites for both states. This was a good opportunity for Louisianans to hear about things like the recent work at the Carson Mound site and for Mississippians to hear about recent archaeology in New Orleans (to pick a small sample of many fine examples). Dr. Vin Steponaitis of the University of North Carolina was the key-note speaker who made an excellent presentation on the Feltus Mounds site.

Another special part of the meeting was the tour on Sunday morning of several early historic and prehistoric sites in the Natchez area. Of particular interest were the Feltus Mounds, the Grand Village of the Natchez, the site of Fort Rosalie, and Emerald Mound. Tour guides included “Smokey” Joe Frank, John O’Hear, Vin Steponaitis, and Jim Barnett.



Stacie Palmer of the LA Division of Archaeology barely contains her excitement while registering at the meeting.

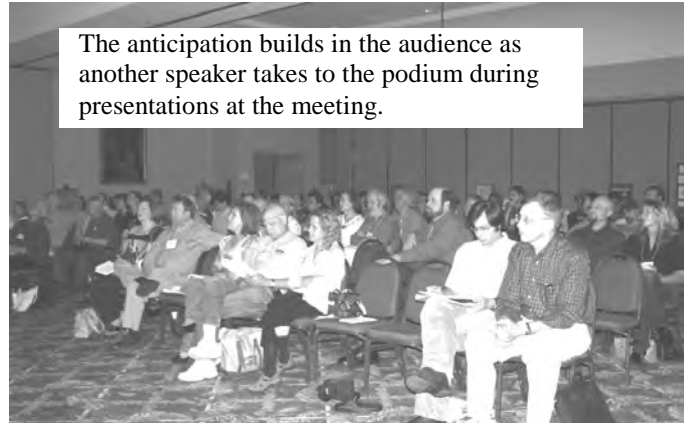

The anticipation builds in the audience as another speaker takes to the podium during presentations at the meeting.

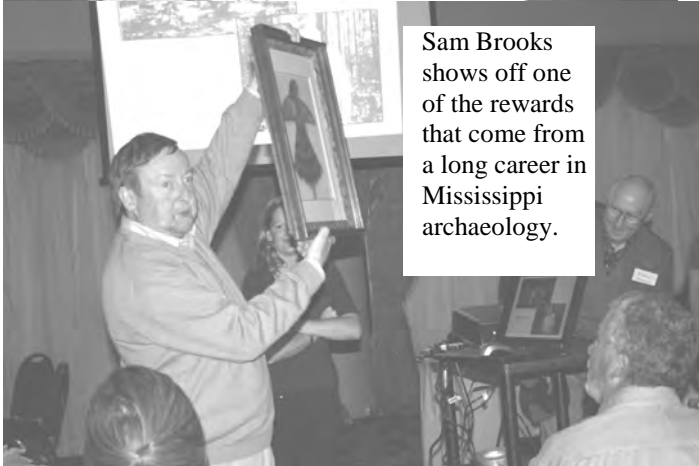

Sam Brooks shows off one of the rewards that come from a long career in Mississippi archaeology.

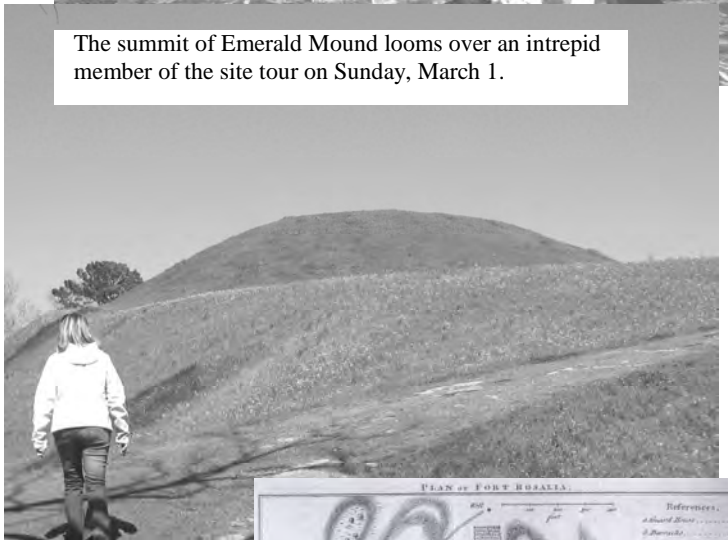

The summit of Emerald Mound looms over an intrepid member of the site tour on Sunday, March 1.



Vin Steponaitis discusses the length of the “one that got away” at the Feltus Mounds during the site tour on March 1.

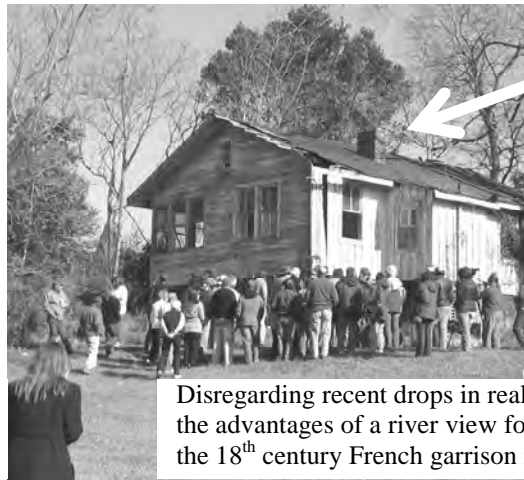

Disregarding recent drops in real estate values, many on the site tour listen to the advantages of a river view for a “fixer upper” at the site of Ft. Rosalie, the 18th century French garrison in Natchez. Note original site plan above.

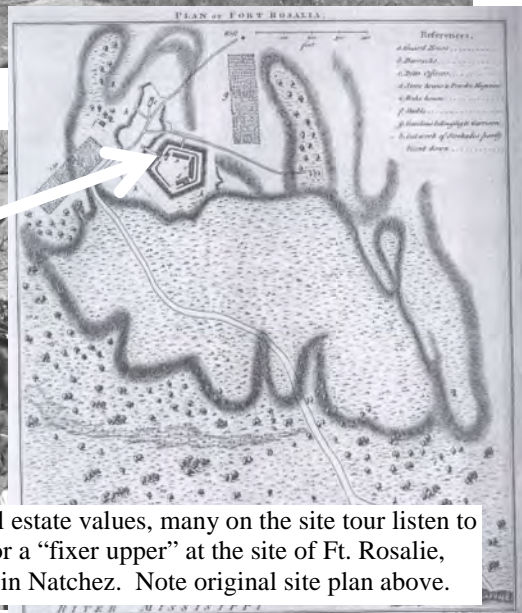

Editor's Note-

Dr. Shannon Dawdy, once with the Greater New Orleans Archaeology Program and now on the faculty of the University of Chicago, nominated Bettie Pendley, a long time member of the LAS, for the society's Saucier Award. This award is to recognize non-professionals who have made valuable contributions to archaeology in Louisiana. Below are excerpts from Shannon's letter to then LAS president George Riser extolling Bettie's achievements and making an irrefutable case for why she deserved the award. Congratulations to Bettie from the LAS and all who benefitted from her efforts.

(left to right) Dr. Shannon Dawdy, Bettie Pendley, and Mary Beth Ray (Bettie's daughter), pose after Bettie receives the LAS Saucier award at the 2009 meeting.



Dr. George Riser

December 4, 2008

President, Louisiana Archaeological Society

Dear George,

I am writing to you in your capacity as current president of the Louisiana Archaeological Society. Via this letter, I would like to nominate Mrs. Bettie Pendley as a candidate for the 2009 LAS Saucier Award. In order to assist the Executive Committee in its consideration of this nomination, I will offer an account of Bettie's extraordinary contributions as an avocational archaeologist and preservation activist. For over 30 years, Bettie Pendley has worked vigorously as a volunteer and advocate for historical archaeology in the state, and especially for public support of projects in the New Orleans metro area. I believe her record fits the LAS's description of the Saucier award: "to honor those individuals who, while not having a career in archaeology, none-the-less found the time and energy to make a substantial contribution to the field," especially under the third criterion, "having a substantial record of supporting archaeology and the Louisiana Archaeological Society by serving in the organization, providing educational opportunities in non-traditional settings (presentations to schools, developing LAS chapters), and/or repeatedly working with or helping to arrange funding for archaeological investigations." She has done all of these things, and done them well.

This account will necessarily be partial, dating only to my own acquaintanceship with Bettie. And it will further be biased towards the interactions I've personally had with her and the accomplishments which I have witnessed and benefited from since I met her in 1994. I know that her accomplishments date much further back. If not a charter member of the Delta Chapter of the LAS, she was certainly one of its earliest active members in the 1970s, and served as an officer several times. There are colleagues who share my admiration of Bettie's devotion and hard work on behalf of Louisiana archaeology such as Duke Rivet and Nancy Hawkins in the Louisiana Division of Archaeology, Dr. Jill-Karen Yakubik of Earth Search, Dr. Timothy Joder, formerly of U.N.O. and Priscilla Lawrence, Executive Director of the Historic New Orleans Collection. I also know that the late John Polk and the late Tom Eubanks would have whole-heartedly supported this nomination. In fact, I had already discussed this possibility with Tom weeks before we were all sideswiped by the 2005 hurricanes, and by Tom and John's illnesses that followed. I regret that it has taken me this long to write this letter to follow up.

Bettie's interest in archaeology began overseas, visiting sites in Europe and working as a volunteer in Israel. After visiting Colonial Williamsburg that she realized it was possible to do archaeology right at home. She began volunteering on excavations led by Dr. Richard Shenkel, Dr. Richard Beavers, and other local professionals through both her Delta chapter affiliation and her pursuit of studies at U.N.O. in the Anthropology Department and the former College of Urban and Public Affairs. It was after becoming a fixture on the U.N.O. campus that she was convinced by the faculty and staff to transform her ideas to promote urban archaeology in New Orleans into a master's thesis entitled,

Shannon Dawdy's Nomination of Bettie Pendley for the LAS Saucier Award (continued)

"A Framework for Implementing a Comprehensive Archaeological Program in New Orleans, Louisiana," (College of Urban and Public Affairs, University of New Orleans, 1992). She earned this degree around the age that most people enter retirement, but she had just gotten going.

Bettie was instrumental as a fund-raiser, deal-maker, field-volunteer, and public ambassador. During the three and a half years that I directed the program, she helped build our corps of volunteers to 50 strong and, more importantly, raised the profile of archaeology in the city in a way that had never been done before by cultivating contacts with the local media, and promoting archaeology to the Vieux Carré Commission and Historic District Landmarks Commission. She was instrumental in making sure the Louisiana State Museum observed its responsibilities during renovations of Madame John's Legacy in 1997, resulting in the fabulous discovery of a trash pit dating to the 1788 fire that devastated the city and gave us our first significant floral and faunal data from a colonial New Orleans context.

Bettie has performed this brave campaigning and savvy networking, however, not for recognition. In fact, although she's never shy about voicing her opinion, she rather shuns the spotlight. Still, when I tire of talking to the 100th tourist coming by the site who asks, "Found any gold yet?," as they did while we dug behind St. Louis Cathedral this summer, I can always turn to Bettie to step in as public liaison. With evangelical relish, she seizes each opportunity to gain a new convert to archaeology, no matter what their walk of life. I have heard her captivate street cleaners, children, nuns, politicians, drunk tourists, and construction workers and even (sometimes to my initial alarm) invited them to help us excavate. It is hard to say "no" to Bettie's enthusiasm for archaeology. You just don't deny something to a person who has such a passion that she makes the rest of us feel like we don't care enough.

Obviously my own career has benefited directly and substantially from Bettie Pendley's tireless efforts. But I would not be forwarding this nomination if I did not believe that the greater good she has achieved has been to make Louisiana archaeology more public, more responsible, and more interesting. I think she has also converted, in her way, thousands of individuals to support urban archaeology. I hope you will agree with me that she has earned the recognition of her peers at the Louisiana Archaeological Society and I'm sure she would be honored to receive an award named for her friend, Roger Saucier. Precisely because she doesn't seek recognition, I think she deserves it all the more.

With regards,



Shannon Lee Dawdy
Assistant Professor-University of Chicago

**Baton Rouge Chapter
Dennis Jones-President**

The BRLAS continues to have its meetings at the Bluebonnet Branch of the East Baton Rouge Parish Library. We have had several great speakers lately.

In January State Archaeologist, Dr. Chip McGimsey, told a rapt audience about his and Diana Greenlee's visit to Naples, Pompeii and Herculaneum.

For February, Dr. Rob Mann, SE Regional Archaeologist, brought us up to date on his work at the Galvez Town site which was a Spanish colonial settlement on the Amite River in Ascension Parish that dates to the late 18th century.

In March, Dr. David Chicoine, a new faculty member at LSU, gave a wonderful presentation about the southern periphery of the Moche' culture in Peru. He had a very interesting report on a prehistoric culture that developed in a desert setting, between the fourth and sixth centuries A.D.

In April, Becky Saunders, of the LSU Museum of Natural Science and the Dept. of Geography and Anthropology gave an insightful roundup of the research that has been done at the Bayou Grand Cheniere Mounds (16PL159). This multi-mound site sits enigmatically and literally at the end of the earth. Tim Schilling wrote an article about the site in the last LAS newsletter.



Ellis H. Denning

Mr., Ellis H. Denning, was born October 27, 1919, in Oklahoma City, Oklahoma, to his late parents, J. R. and Nelle Denning. He is preceded in death by wife, Sybil Gayle Spinks Denning and a sister, Alice Rose Denning. He leaves to cherish his memory, a son, Paul Denning, and his wife Ruby; a granddaughter, Mindy and numerous nieces and nephews and other family members and friends. Mr. Denning retired after many years of service with Conoco/Phillips Oil Co. where he worked as a geologist. He was a resident of the Pineville/Alexandria area for 30 years where he was a member of Philadelphia Baptist Church, Libuse, and **the Louisiana Archeological Society, Central Louisiana Chapter**. He was a frequent volunteer at Ruby Vise Elementary School. A memorial service celebrating the life of Mr. Ellis H. Denning was held at 10 a.m., Monday, October 13, 2008 at Philadelphia Baptist Church. Interment was in the Zion's Rest Cemetery, Pleasant Hill.

-from the Alexandria Town-Talk

NORTHEAST LOUISIANA ARCHEOLOGY SOCIETY

Claire Davis-President

Thursday, March 19, 2009 6:45 pm

Our traditional yearly party!!

We brought good food to share. We also brought artifacts or other interesting things to look at and to study. We will talk for a little while about the past and future of our society. We had 13 members also take a guided tour of the History Museum where our meetings are held.

Thursday, April 16, 2009, 6:45pm

Diana Greenlee, PhD., Station Archeologist at Poverty Point, talked about the field projects at Poverty Point that are scheduled for May and June this year. She also made a presentation entitled "Big, Beautiful and Built" about how some new scientific instruments have provided answers to some of the mysteries of the site.

Contact Claire Davis @ cdavis1021@comcast.net for more information about the northeast LAS chapter.



Members of the Caddo Nation provide the rhythm for the Turkey Dance at the 2009 Caddo Conference.

The **51st Annual Caddo Conference** was held on March 12-14, 2009 at the Sam Noble Oklahoma Museum of Natural History in Norman, Oklahoma. Papers were presented by members of the Caddo nation, archaeologists, other professionals, and students from Oklahoma, Arkansas, Louisiana, and Texas. Jeff Girard of the Northwest Regional Archaeology Program spoke on copper artifacts from the Gahagan and other sites in the southern Caddo area and Charles M. Allen, now working at Fort Polk, made a presentation entitled: "Identification of Native Plants Use by the Caddo Tribe in Their Homeland." In addition to these two speakers, other Louisiana attendees included Duke Rivet, Bob Neuman, Brad Lafitte, and Jim Grafton. Next year's Caddo Conference will be held at the University of Texas at Tyler next March 18-20, 2010. More information will be forthcoming.

Mark Walters [mwalters@wildblue.net] is planning the conference.

Jessica Crawford
Southeast Regional Director
The Archaeological Conservancy

The Archaeological Conservancy recently purchased a small lot in Jonesville, Catahoula Parish, LA that contains the remains of mound 4 (Figure 1) of the Troyville site (16CT7). Joe Saunders, Recca Jones and some volunteers put in a unit there a few years ago and I remember it was full of pottery (Figure 2). There are also a few historic graves on the lot that date to the late 1800's and early 1900's. There was a small house on the lot and the owner recently tore it down and we agreed to finish cleaning it up. I hope this lot will be the first of several parts of the Troyville site the Conservancy is able to acquire.

Much of the cost of the site was covered by donations made to the Conservancy in memory of Tom Eubanks, past State Archaeologist of Louisiana. Tom worked on many projects and was a great friend of ours. I want to thank everyone who chose to honor his memory by donating to the Conservancy. We are looking forward to cleaning up the lot, fencing & landscaping it and eventually placing a plaque at the site honoring both Tom and the previous owner's family.

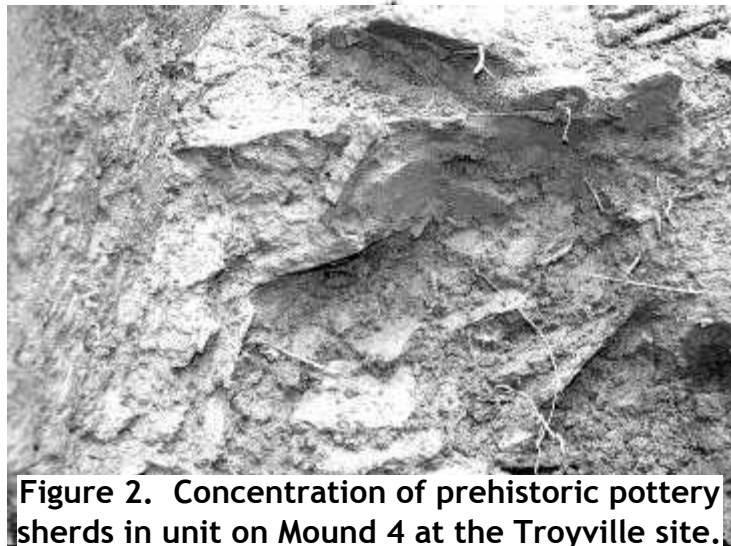
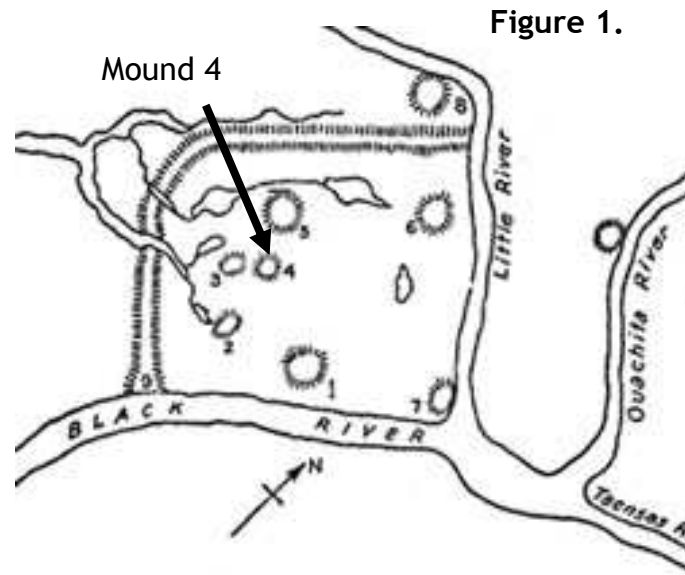

News from the Louisiana Archaeological Conservancy (LAC)

Rob Mann and Dennis Jones made a detailed contour map of what remains of the Highland Rd. Stockade site (16EBR) in Baton Rouge. Portions of this site, a small garrison and check point during the Federal occupation of Baton Rouge, has been protected by a Preservation Servitude through the LAC since the early 1990s.

Contacts have also been initiated with a representative for the owners of the King George Island Mounds site (16LV22) in Livingston Parish. Additional mounds have been found and investigated making the site even more complex than previously realized. There are four, possibly five, mounds on two islands that were once ridges that have since subsided into the swamps west of Lake Maurepas. Currently, the mounds are thought to date to the Archaic.

There have also been discussions with one of the landowners in pursuit of a Preservation Servitude for the remaining portions of the Lake St. Agnes Mound site (16AV26) in Avoyelles Parish. This site was investigated in the 1970s by Dr. Alan Toth, a former State Archaeologist for Louisiana.

LOUISIANA DIVISION OF
ARCHAEOLOGY

The State of Louisiana Archaeology - 2009

By Chip McGimsey-State Archaeologist

2008 was a busy year for the Division of Archaeology and for Louisiana archaeology in general. We are all still dealing with the effects of Hurricanes Katrina and Rita, although fortunately, Hurricanes Gustav and Ike from the fall of 2008 had little impact on cultural resources. One of the Division's responsibilities is to review each federally funded, permitted or licensed project for its possible impact upon archaeological sites. The number of projects dramatically increased after the 2005 storms and remains at a very high level. We anticipate the number of projects will remain high for a few years to come. As a consequence of the number of projects, the number of survey, testing and excavation reports that have come to our office for review also remains well above normal, as does the number of sites being recorded and updated. As of February 2009, there are approximately 17,500 sites recorded across the state.

After many years of effort by Joe Saunders, Recca Jones, Nancy Hawkins, Joretta LeBoeuf and many others, the Ancient Mounds Heritage Trail is completed. The Driving Trail Guide has been printed (72,000 copies) and distributed to visitor's centers and tourist centers across the state. Anyone can receive a copy of the Driving Guide by contacting our office (225-342-8170) or by visiting our website (www.crt.state.la.us/archaeology). The Mounds Trail consists of 39 Native American mound sites in northeastern Louisiana that are visible from public roads; they include three State Historic Sites, three sites owned by the Archaeological Conservancy, and 33 sites maintained by private landowners. At each site, there is a historic marker along the highway to denote its location. The Driving Guide provides a map and brief description of the site and what is known about it. The Mounds Trail is a wonderful opportunity to see some of the magnificent mound sites that dot Louisiana's landscape, and to promote awareness of our fascinating history to citizens and visitors alike. I hope everyone will take advantage of this trail to explore our archaeological history whenever they visit the northeastern part of the state.

Archaeology Month 2008 featured the Mardi Gras shipwreck on the poster. This wreck was found off the coast of Louisiana at a depth of 4,000 feet, and was excavated using a remotely-controlled vehicle (illustrated on the poster). The wreck is believed to be the ship *Rapid*, a War of 1812 privateer that capsized and sank in November 1813 while being chased by the British warship *HMS Herald*. The artifact collection has been donated to the Division of Archaeology and will be featured in a forthcoming exhibit at the State Museum in New Orleans.

The Division's Curation facility is currently located in the basement of the Galvez Building in downtown Baton Rouge. During heavy rains when the wind is from the right direction, the building leaks and water collects on our storage floor. Standing water in a collection facility is not a good thing. Fortunately, the Office of State Buildings has found us a new facility, and if all goes well, during the fall of 2009 our collections will be moving. The proposed new facility is on the second floor of a building, and in addition to a dry floor, also provides significant additional space for new collections. This is critical since the current facility is full and we have run out of room for new collections.

The future of the Division of Archaeology is cloudy as of this writing. The Governor's proposed budget for next year would severely impact the Division and the staff available to fulfill its duties. It remains to be seen how the budget process will play out and how the Division will be affected. Despite this uncertainty, the Division has been working steadily on revising the standards for archaeological fieldwork and project reports and hopes to have those completed later this year. In a similar vein, we are hoping to receive funding to begin the process of developing a new statewide archaeological plan. The state plan will provide a summary of the state of archaeological knowledge across the state, identify key areas for future research, identify critical sites for protection and preservation, and serve as a guide for determining which sites are potentially eligible for nomination to the National Register of Historic Places. When this project gets underway, we will be looking for input and assistance from all professional and avocational archaeologists and other interested folks. Stay tuned to the newsletter for future details.

The future for archaeology in Louisiana looks promising. CRM archaeology is actually a growth industry in the state with the value of contracts to private firms increasing substantially over the last six years. With continued hurricane recovery projects and new projects developing from economic stimulus projects, we anticipate the

The State of Louisiana Archaeology (continued)

value of archaeological projects will only increase for the immediate future. One of the major projects ongoing at this time is the development of the Veteran's Administration hospital and LSU Medical Center complexes in New Orleans. Together these two hospital complexes will take over 24 city blocks within the Mid-City Historic District. Development of this part of the city began as early as 1840, but really took off after the Civil War. The archaeology that comes from these projects should provide an illuminating look at the lives and livelihoods of New Orleanians over the last 150 years.

In addition, there will be some exciting projects at various state historic sites. Later this spring, portions of the Marksville site will be explored with ground-penetrating radar as part of a training project for members of the Louisiana Army National Guard. The National Park Service will be hosting a training session for people from around the country at Los Adaes and Fort Jessup to train them in the use of various remote sensing technologies. A similar remote sensing project is slated for the Mansfield Civil War battlefield in an effort to locate several of the mass graves dug after that battle. Another project will be at the Port Hudson Civil War battlefield and will be looking for one of the Union army's sapper trenches aimed at the Confederate Fort Desperate. And finally, but certainly not least, Poverty Point will be hosting a field school exploring some of the large rings that have been discovered as a result of remote sensing at the site over the last 4 years. These rings lie in the plaza area and represent a previously unknown element of the site whose function and purpose are completely unknown.

The latest on the Professional Archaeologists of Louisiana (PAL)

Announced in the last LAS newsletter and in emails to well over 100 people, professional archaeologists working in Louisiana were invited to an organizing meeting to form an organization supporting the profession and science of archaeology in the state. This meeting was held during the LAS/MAA meeting in Natchez, MS immediately following the general business meeting of the LAS. About 30 people gathered to discuss the viability of such an organization, its orientation, purpose, and membership requirements. Others who were unable to attend the meeting sent messages of support. Many in attendance had experience with similar organizations in Mississippi, Florida, Texas, Wyoming and British Columbia. Most in attendance at this meeting agreed that the archaeological community of Louisiana would benefit by such an organization and supported its formation.

Martin Handly of URS Corporation, Baton Rouge; David Kelley of Coastal Environments, Inc, Baton Rouge; and Dennis Jones, Louisiana Division of Archaeology, Baton Rouge; having initially made the call for such a meeting, led the discussion. Many ideas and accounts of experiences with similar organizations from numerous people provided direction for the group. By acclamation of those attending, Martin Handly was selected as the president of PAL, David Kelley, Vice President, and Dennis Jones, Secretary/Treasurer.

Martin, David, and Dennis proposed that they would pursue the incorporation of PAL as a 501 (c) 3 non-profit organization in both Louisiana and with the Internal Revenue Service. In addition, they planned to construct a mission statement for the organization as well as a set of by laws. Both documents will be presented before the potential membership for input and ratification. As of this writing the incorporation papers have been submitted to the Louisiana Department of State and approval is pending.

Interested folks can look at the websites of similar organizations. Please check them out.

Wyoming - <http://www.wyowapa.org/>

Texas - <http://www.counciloftexasarcheologists.org>

Arizona - <http://arizonaarchaeologicalcouncil.org/aac/>

Kansas - <http://www.ksarchaeo.info/home.shtml>

Florida - <http://www.flarchcouncil.org/fac.htm>

Editors Note- Since the early 1980s, the LSU Campus Mounds (16EBR6) have been the scene of occasional archaeological investigations, but surprisingly little is known about a site located on the grounds of the largest university in the state. While no major excavations have ever been conducted at the site, earlier core samples date the mounds to around 5000 years ago. Listed on the National Register of Historic Places since 1999, recent remote sensing studies and additional cores should either corroborate their supposed antiquity or cause archaeologists to reconsider the site's age. Below is a message from LSU faculty and Louisiana Antiquities Commission member, Heather McKillop. An article that appeared in the Baton Rouge Morning Advocate on April 16, 2009 is on the next page.

From the Chair of the Louisiana Antiquities Commission:

An interdisciplinary team of researchers from LSU, ULM, and the Division of Archaeology cored the LSU Campus Mounds on Wednesday 15 April 2009 (see photos). The fieldwork was carried out under permit from the LA Antiquities Commission to Dr. Rob Mann, SE LA Regional Archaeologist and Faculty member in the LSU Dept of Geography and Anthropology. The research developed from fieldwork carried out under permit from the Antiquities Commission to Dr. Brooks Ellwood, Professor in the Dept of Geology and Geophysics at LSU. With students enrolled in his Geoarchaeology course in the fall of 2008, Dr. Ellwood carried out remote sensing on the mounds and encountered an "anomaly." Dr. Ellwood gathered together a team of experts, including Dr. Mann, Dr. Rebecca Saunders (Associate Professor in the LSU Dept of Geography and Anthropology, Dr. Joe Saunders (NE Regional Archaeologist with the LA State Division of Archaeology at ULM), Mr. Thurman Allen (retired Soil Scientist with the USDA). A core was successfully taken from each of the LSU Campus Mounds. The LA Antiquities Commission is excited about the interdisciplinary research and looks forward to presentations and publications on the findings at these important mounds.

Heather McKillop, William G. Haag Professor of Archaeology
Dept of Geography & Anthropology, Louisiana State University



All photos taken by Heather McKillop
A) Rob Mann labels a portion of the core taken from Mound A. B) Brooks Ellwood (l) prepares to extract the soil from the core sample as Joe Saunders joins the effort. C) (l-r) Ellwood, Thurman Allen, and Saunders prepare to take another core sample from the interior of Mound A at the LSU Campus Mounds site (16EBR6).

Archaeologists test ‘charcoal horizon’ at LSU

By Jordan Blum, Capitol news Bureau

Baton Rouge Morning Advocate-April 16, 2009

While studying the ancient LSU Mounds with his geo-archaeology class last semester, LSU professor Brooks Ellwood discovered an “anomaly” deep inside. That discovery led to a team of the state’s top archaeologists on Wednesday taking core samples more than 5 meters — about 17 feet — deep into the 5,000-year-old mounds built by early American Indians. It was the first deep sampling since the mounds were first dated in 1982.

“This was a big surprise, this huge anomaly,” Ellwood said Wednesday after preliminarily analyzing a “charcoal horizon” detected in the core samples that might have caused the anomaly. “It’s a localized burn, so it could be a pit barbecue,” Ellwood said, “or it could be — although it’s never been seen — they cremated someone there.” The hope is to learn more about the exact age of the mounds, how they were built and, how long it took and why, he said. Pollen also will be studied to learn clues about the climate back then, he said.

The mounds, commonly called the Indian Mounds, are believed to have been used for ceremonial and marking point purposes, said Rebecca Saunders, archaeology professor and associate curator of the LSU Museum of Natural Science. “I don’t think people really understand these are our pyramids,” Saunders said. “The only thing is they don’t have stones.”

Less than three decades ago, no one believed mounds were built 5,000 years ago in North America, she said. The belief was that everyone was more nomadic hunters and gatherers and that agriculture and tribal chiefs were needed before structures would be built. Louisiana is home to hundreds of prehistoric American Indian mounds that are among the oldest in the continent. The two LSU Mounds are listed in the National Register of Historic Places. In trail guides, Lt. Gov. Mitch Landrieu touts many of the mounds as far older than the Egyptian pyramids or Stonehenge.

Heather McKillop, geography professor and Louisiana Archaeological Survey and Antiquities Commission chairwoman, said the mounds are often taken for granted. “These mounds are here, and we walk past them all the time,” McKillop said. “But they’re incredibly important historically to the state. Getting everybody together here is a real exciting opportunity.”

T.R. Kidder, mounds researcher and anthropology professor at Washington University in St. Louis, has described Louisiana as “New York, London and Tokyo all rolled into one” for North America prior to 1,000 B.C. The Lower Mississippi delta region was much of the continent’s foundation for early human life, Saunders said.

Still, Ellwood said, so little is known about these mounds that anything learned is great news. The northern LSU mound is made partly of more porous dirt and more saturated with water, he said. The southern mound has harder clay dirt. Despite the differing materials, Ellwood said, data suggest they were built simultaneously and they have similar markers from when extended breaks were taken during construction. The ancient people would build portions, travel for months and then return. “We know very little about them and the people who made them,” Ellwood said. “We don’t know what all they were used for. And why did they build paired mounds?”

There are many false myths about the mounds as well, Saunders said. One popular myth was that the mounds were dirt kicked back from the excavation of the old Huey P. Long Pool on campus. The state’s oldest mounds though – the Monte Sano mounds north of the state Capitol – have been destroyed but were about 7,000 years old, Saunders said. What are believed to be the oldest surviving mounds in the state are the Frenchman’s Bend and Watson Brake mounds near Monroe, she said, which are thought to be close to 5,500 years old.



Can you dig it? Volunteers restore looted 800-year-old site

BY ROBERT MORGAN • RMORGAN@THETOWNTALK.COM • MARCH 29, 2009

PINEVILLE -- It was called an archeological dig, but it was more of a fill, according to Velicia Bergstrom, U.S. Forest Service archeologist. Volunteers came from all over the country to participate in the archeological dig in the Kisatchie National Forest near Fort Polk, U.S. Forest Service officials said. Jim Caldwell, public information officer for the Forest Service, said there were people from as far away as Chicago, Ill., and other states, in addition to volunteers from the local area.

Bergstrom said the dig was part of the Passport in Time program, commonly referred to as PIT, a national program that draws volunteers from across the nation and occasionally other countries to help restore and maintain historical sites. The recent project in the Vernon area of Kisatchie National Forest drew 32 volunteers, she said.

The 2-acre site near Gum Branch had been looted several times since the 1980s, she said, adding the site had been looted when it was found in 1989. Again in 1999, when Pan American Engineers had contracted to do a project for the military, even more looting was discovered, she said. "In 2004 there was some major looting," she said, explaining looters had dug up the site of a prehistoric camping area in search of points (flint arrow and spear points) and other artifacts for possible sale or private collection. "We found one dig that was 4 meters by 8 meters by 30 centimeters (approximately 15 feet by 30 feet and 10-12 inches deep)," she said.

She said the group found evidence that the site had been used as a regular camp site by Native Americans dating back 1200 A.D. "We found a hearth. We found what we thought was a (rotted) post hole. It turned out to be a smudge pot where they burned something," she said.

Despite the previous looting, she said the PIT group found more than 9,000 recorded artifacts, including several points, flakes of flint and pieces of pottery. "We mitigated some of the looting by restoring some of the land," she said, explaining the primary purpose of the project was to put the site, as near as possible, back in the condition it was in before the looting.

Caldwell said many of the volunteers had positive things to say about their experiences. Gail Pyndus of Chicago said, "This Kisatchie National Forest experience has been wonderful. I would definitely come back."

Bergstrom said it appeared the site was used by a group of 25 to 30 people, returning at regular intervals, perhaps spending 3 to 4 months each year hunting before moving on to other areas. One volunteer sifted soil in an effort to find information, including seeds of various kinds that could tell something about the nature of the site 800 years ago, before it was built up and covered over with shifting dirt and rotting vegetation, she said.

But Bergstrom said not much will be known about the site's actual use until lab work is completed in the fall. "That's when you put the pieces of the puzzle together. The lab is my favorite part," she said.

Regional Archaeology News

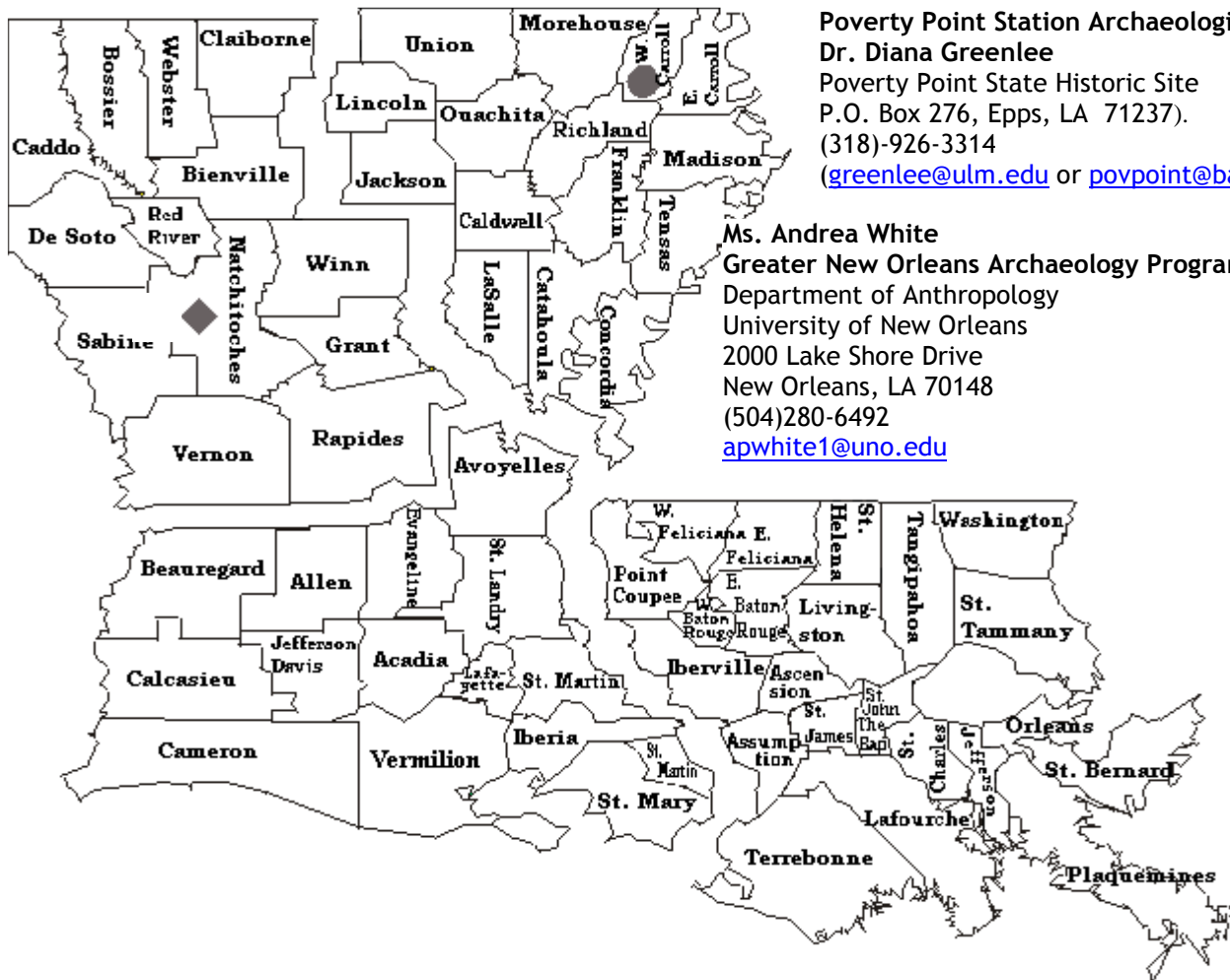

Poverty Point Station Archaeologist
Dr. Diana Greenlee
 Poverty Point State Historic Site
 P.O. Box 276, Epps, LA 71237.
 (318)-926-3314
 (greenlee@ulm.edu or povpoint@bayou.com),

Ms. Andrea White
 Greater New Orleans Archaeology Program
 Department of Anthropology
 University of New Orleans
 2000 Lake Shore Drive
 New Orleans, LA 70148
 (504)280-6492
apwhite1@uno.edu

Northwest Region
Mr. Jeff Girard
 Regional Archaeology Program
 Department of Social Sciences
 Northwestern State University
 Natchitoches, LA 71497
 (318) 357-5471 girardj@nsula.edu

Southwest Region
Dr. David T. Palmer
 Regional Archaeology Program
 Department of Sociology and
 Anthropology
 University of Louisiana Lafayette
 Lafayette, LA 70504
 (337) 482-5198
dtpalmer@louisiana.edu

Northeast Region
Dr. Joe Saunders
 Regional Archaeology Program
 Department of Geosciences
 University of Louisiana - Monroe
 Monroe, LA 71209
 (318) 342-1899
saunders@ulm.edu

Southeast Region
Dr. Rob Mann
 Regional Archaeology Program
 Museum of Natural Science
 Louisiana State University
 Baton Rouge, LA 70803
 (225) 578-6739
rmann1@lsu.edu

Northeast Regional Report
Dr. Joe Saunders
University of Louisiana, Monroe

A flurry of activities took place in northeast Louisiana since the end of the year. An interim class in Archaeology Field Methods was conducted with three students: Norma, Brooks, and Stephanie. Each one became adept at working in wet and cold weather. We conducted limited testing at the Plum Creek site (16OU89), but unfortunately the Middle Archaic midden had been virtually destroyed.

Next, auger probes were excavated at Frenchman's Bend Mounds to locate a midden deposit near the bottom of Mound A. The auger probes were about 3 m deep, and the fill was difficult to process. Finally, we located a midden deposit, 60 cm deep on the south flank of the mound. Unfortunately, the "find" occurred on the last day of the interim session.

Additional work was conducted at Frenchman's Bend Mounds with avocational archaeologists Kelby Ouchley, John Norris, and Bruce Schuster, as well as Recca Jones. A 1 x 1 m test unit, two 1 x .5 m, and one .5 x .5 m unit were excavated to expose a possible feature in Mound A and to recover fauna from the midden in/under Mound A. The feature in Mound A was insignificant, but fauna was recovered from the smaller units. Snail (*Campeloma*) was the most abundant species, followed by mussel, fish, and small mammal. Snail from the excavations will be submitted for radiometric dating.

Bill Atkins reports that the Town of Jonesville is proceeding with plans to build a large replica of the Great Mound of Troyville with the dirt from the original mound. He has consulted with the Jena Band of Choctaw Indians and they support the project.

The replica will be erected next to US 84 on Catahoula Parish school board property. Mrs. Freeman, Catahoula School Superintendent, has embraced the replica project and is going to include the Native American heritage of Catahoula Parish into next year's grade school curriculum. For those interested in the "Great Mound" project, a 5 minute video about Troyville can be viewed at CatahoulaHistory.com.

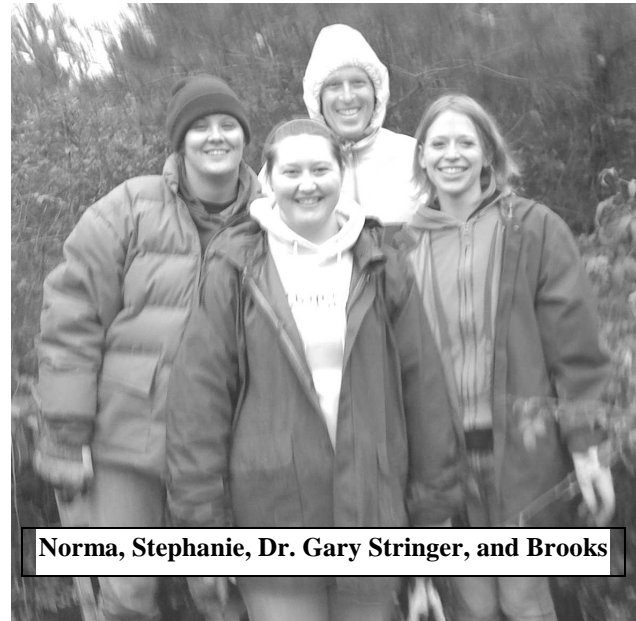

Norma, Stephanie, Dr. Gary Stringer, and Brooks

**Stephanie with
Archaic Point from
Plum Creek**

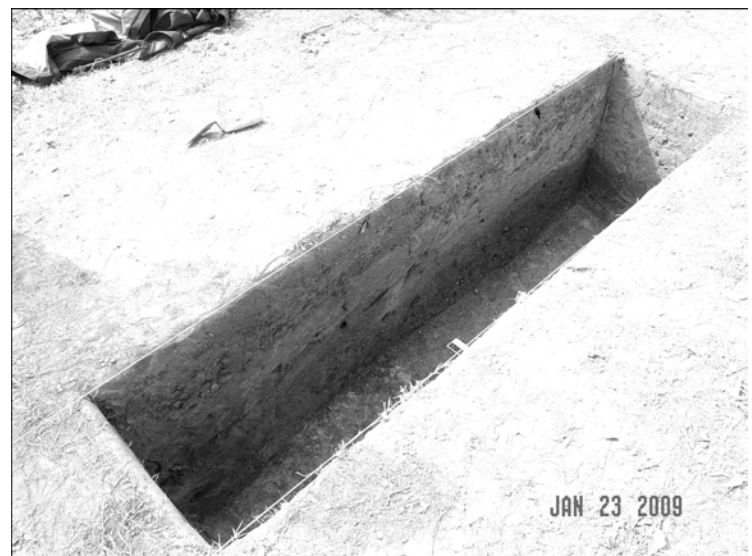

Test Units 5 & 6 at Plum Creek. Midden is the bottom stratum.

Brick Brigade at the Old State Capitol Site (16EBR08)
Dr. Rob Mann, Southeast Regional Archaeologist
Department of Geography and Anthropology
Louisiana State University

In April 2008 the Old State Capitol in downtown Baton Rouge (Figure 1) was in the midst of a major preservation and repair program, which included the restoration and renovation of the cast iron fence that surrounds the five acre tract upon which the Old State Capitol was built. The Gothic Revival capitol building was built between 1847 and 1852 and is now a National Historic Landmark. It was placed on the National Register of Historic Places in 1974. The fence was originally cast and erected in 1855. The fence was constructed of interlocking parts and each section of the fence had to be removed and sent off for restoration. The removal of the interlocking sections of the fence required that the old footings that support the fence be exposed with earthmoving equipment and these activities exposed material culture related to the occupation of the grounds of the Old State Capitol (and perhaps earlier occupations) as well as construction materials related to the fence, mostly bricks. Memory Seymour, Director of Education at the Old State Capitol, contacted the Louisiana Division of Archaeology concerning the artifacts being found as a result of the fence restoration project. On April 20, 2008, Nancy Hawkins, Meta Pike, and I visited the Old State Capitol (which is designated site 16EBR08) to examine the fence restoration project and the artifacts found at the site. A wide variety of artifacts had been picked up from the fence restoration back dirt piles. I examined a large sample of these artifacts. Historic ceramics include creamwares, pearlwares, whitewares, and ironstones. Decorative motifs include transfer printed, edge decorated, hand painted, and cut-stamp decorated. These artifacts are common on sites dating to the nineteenth century. Bottles and bottle glass found at the site date mostly to the nineteenth century and include olive green alcohol bottle bases, an aqua octagonal ink bottle, and a variety of patent medicine bottles and bottle fragments. Two nineteenth century stub-stemmed tobacco pipes were also found. One is a brown stoneware, stub stemmed pipe that might be a ca. 1840 Point Pleasant Ringed Elbow, Variety A style pipe (Murphy 1976). The second is a pale green glazed, white ball clay, human effigy or figurine stub-stemmed pipe (Figure 2). The figure represents a male with a beard and mustache, wearing a turban. It probably dates to ca. 1840 or later and may be French in origin.



Figure 1. View of the Old State Capitol Building in Baton Rouge from River Road.



Figure 2. Human effigy stub-stemmed pipe bowl.

Brick Brigade at the Old State Capitol Site (continued)

These finds prompted the development of a public outreach program for students from two Louisiana middle schools. The program was designed to highlight restoration of the historic fence and the archaeological resources present on the grounds of the Old State Capitol (16EBR08). The program, entitled “Louisiana Old State Capitol Brick Brigade: Mending Fences and Building Community,” was put on by the Old State Capitol Education Department and was sponsored by Secretary of State Jay Dardenne, Jerry Campbell and Associates, Cangelosi-Ward Contractors, and the Office of the Mayor. These sponsors supplied materials for the program as well as t-shirts and lunch for the students. Students from McKinley Middle Magnet School in Baton Rouge and Riser Middle School of West Monroe participated in the program. There were three stations (a simulated dig site, a computer lab where the students played a computer game called “Dirt Detective, Junior Archaeologist,” and an artifact screening station) with hands-on activities set up for the students. These stations were staffed by Nancy Hawkins, Meta Pike, Dennis Jones, and Stacie Palmer from the Louisiana Division of Archaeology, as well as Jessie Cohen and I, who represented the LSU Regional Archaeology Program. Jessie, Dennis, and I staffed the artifact screening station that allowed the students to screen soil from the fence restoration back dirt piles and recover any artifacts present in the screens. These artifacts were collected and brought back to LSU. A variety of materials were recovered from the screened back dirt, including historic ceramics, bottle glass, and faunal (bone and shell) remains, as well as a variety of building construction materials such as nails, window glass, slate roofing, mortar, and (of course) brick.

The artifacts recovered from the Old State Capitol site come from uncontrolled excavations related to the restoration of the historic cast iron fence surrounding the site, resulting in a largely un-provenienced assemblage. Even so, these artifacts do suggest the likelihood that intact subsurface deposits relating to the Old State Capitol (and perhaps earlier occupations) are present at the site.

Reference Cited

Murphy, J. L.

1976 Reed Stem Tobacco Pipes from Point Pleasant, Clermont County, Ohio.

Northeast Historical Archaeology 5(1-2):12-27.

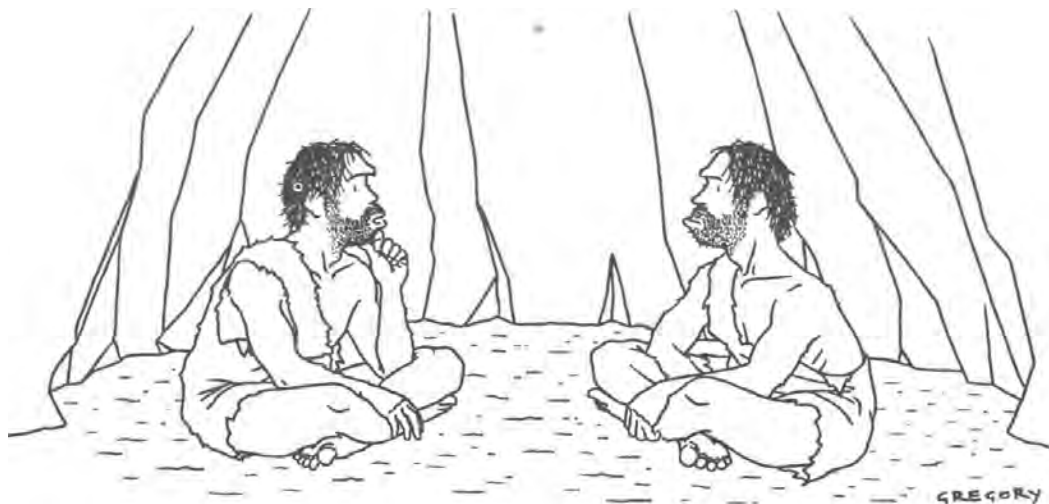

“Something’s just not right—our air is clean, our water is pure, we all get plenty of exercise, everything we eat is organic and free-range, and yet nobody lives past thirty.”

Northwest Regional Report
Jeff Girard
Northwestern State University

The Louis Baker Screen

The following plans are for construction of a field screen designed by Louis Baker, a member of the Northwest chapter of the LAS for more than 20 years. Louis' screens are used by almost all of the regional and station archaeologists in both Louisiana and Arkansas, and he is frequently contacted about constructing more. He has generously supplied the information provided here so that others can make their own screens. The screens are very sturdy and can be easily transported and stored. The figure was assembled from drawings originally made by the late Donald P. Duncan.

Qty	Item	Size
Lumber		
2	2x4	12'
1	1x6	8'
1	1x4	28"
1	1 ½ x ½	12'
Hardware		
4	flat washers	5/16" x 1 ¼"
4	carriage bolts with locknuts	5/16" x 3 ½"
45	dry wall screws	#6 1 5/8"
1	screw (for latch)	#8 2"
124	staples	¼"
1	hardware cloth with reinforced edges	25" x 51"
12	common nails	#16

1. Cut side rail, end rail, and two legs from each 2x4 (see Figure). Cut 1½ x ½ strip into two 51" segments and two 21" segments.
2. Drill 3/8" holes in side rails and legs as shown in Figure.
3. Attach end rails to side rails to form 51" x 25" frame using nails. Note: drill 1/8" holes to start nails to prevent wood from splitting.
4. Staple hardware cloth to frame and secure with 1½ x ½ strips using screws.
5. Attach legs to frame using carriage bolts, washers, and locknuts. Leave nuts sufficiently loose so that legs can be folded.
6. Attach leg braces to legs using screws. Note: the 2.5" distance between the leg bolt and the top of the upper brace is critical so that the legs will open far enough for the screen to be stable.
7. Attach latch (1" x 3" block) beneath side rail so that it can turn to secure legs when folded.

Louis Baker and screen at the Byram Ferry Site 16BO17), Bossier Parish



Editor's Note-

I saw one of these screens years ago being used by people at a Southeast Region project. I was very taken with its portability and ease of use. I borrowed the screen and fabricated one myself using measurements taken from the example I had at hand. It worked great. The only "tweak" I would offer is that there should be a narrow strip of wood, metal, or wire across the bottom of the midsection of the screen to give a little extra support. This is especially important if you're pushing heavy clays through the ¼ inch. Without the strip and the support it provides, the screen will eventually pull away from the sides of the frame.

-Dennis Jones

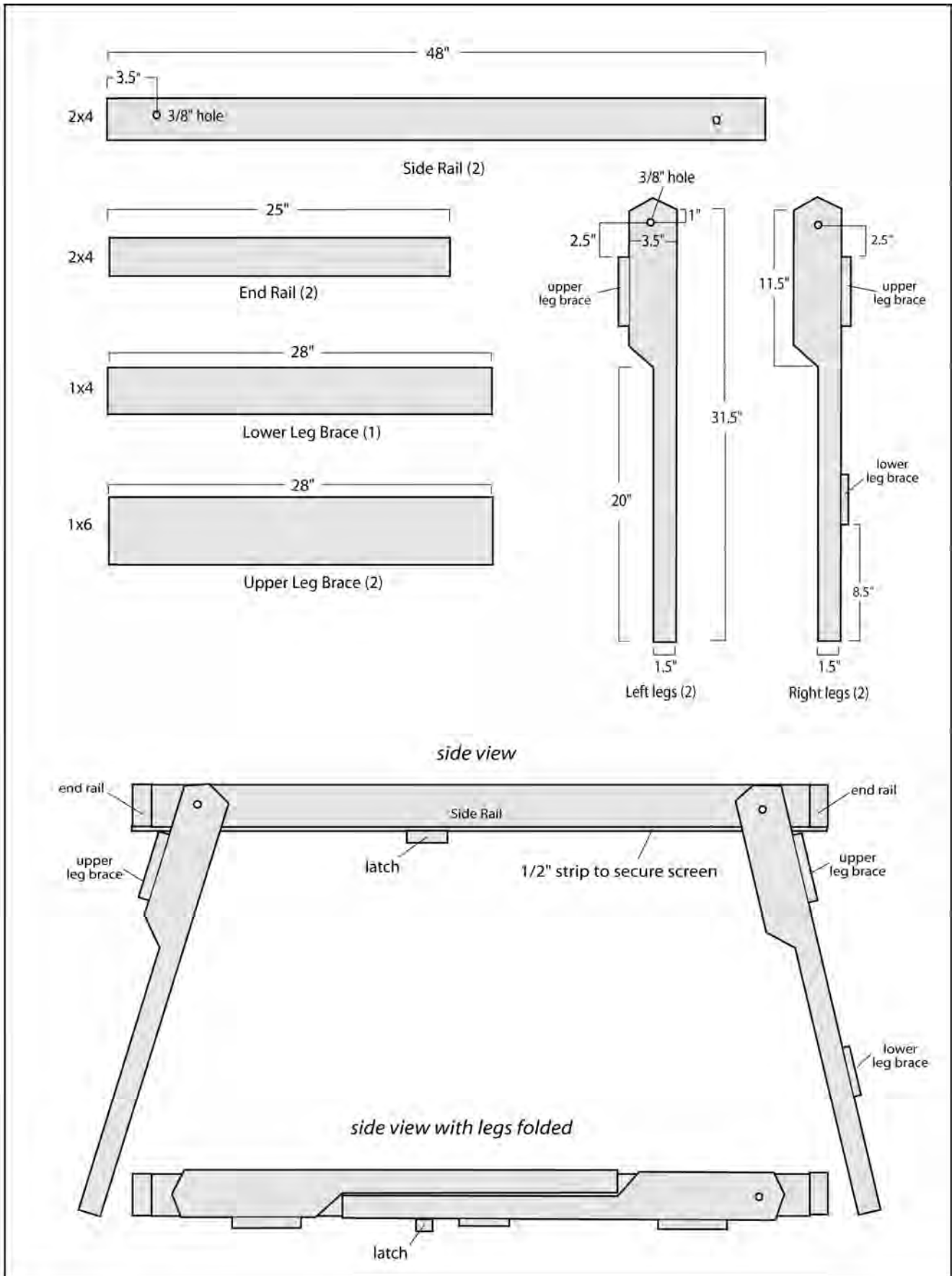

Southwest Region Update

Dr. David T. Palmer, Southwest Regional Archaeologist University of Louisiana at Lafayette

For those of you wondering why you missed me in Natchez, I had a prior commitment as an invited presenter for a conference in South Carolina. During late February, I had the honor of presenting a paper as an invited scholar at the first annual post-doctoral scholar's conference of the South Carolina Institute of Archaeology and Anthropology and the University of South Carolina. Post-doctoral scholar in residence Jodi Barnes organized the conference, which had the theme "The Archaeology of the Recent African American Past". Dr. Barnes is currently reviewing the revised conference papers for an edited volume to be published by the University of South Carolina Press. In addition to the publication, I greatly appreciated the occasion to share ideas with colleagues from all over the country, and to promote the regional archaeology program and archaeological research opportunities in Louisiana. Some of these conversations took place at the popular local restaurant and brew pub, "The Hunter-Gatherer". It may not surprise you to learn that the owner graduated from USC with a degree in anthropology! More information about the conference can be found at this website:

http://www.cas.sc.edu/SCIAA/postdoc_conf.html.

My fieldwork has included testing at Medric Martin's store site near Franklin, Louisiana. You may have seen this store without realizing it, as it was a location for the 1997 movie "The Apostle" with Robert Duvall. Jim Delahoussaye introduced me to Mr. Martin on a tour of the Bayou Teche sugar region last year. Medric Martin, a Louisianan of Acadian or "Cajun" ancestry, at age 95 years, still operates his store six days a week. Possessing a keen wit, he is known to several generations in the Franklin area as well as people from other states and Europe, and counts actor Robert ("Bob") Duvall, former Governor Foster, and actress Whoopi Goldberg among his acquaintances.

Standing country stores in plantation areas are no longer common, but especially not ones whose owner-operators of more than 60 years are still alive and working in the store! For this reason, I made it a priority to record the store as an archaeological site and talk with Mr. Martin about his business. Mr. Martin graciously permitted me to carry out the archaeological testing and to interview him for this project.

Mr. Martin's country store was established in 1870 by relatives from his mother's family. He took over the store in 1935, and has owned and operated it ever since. His store was one of the only independent retail establishments in the area, and served a primarily African American clientele from the local sugar plantations. In 1936 he expanded one side of the store and installed a juke box to create a lounge area for his African American customers. According to Mr. Martin, his customers would spend what little cash they did have with him because he was more polite to them than the plantation owned stores, permitting them to browse merchandise and hang out

at his store. Another reason he mentioned was that he sold alcohol, unlike the plantation owned stores

The fieldwork included mapping, systematic shovel testing around the store, more limited testing below the store, and an oral history interview with Mr. Martin. Although analysis is not complete at the time of writing, I can tell you that the artifacts recovered in and around the store include the expected late 19th to early 20th century materials, namely many alcohol-related artifacts, but also some architectural, medicinal, and other items. Pulling up a board to test below the store porch revealed an abundance of beer cans dating from the 1970s. I was surprised to not find any of the older, punch top and other styles of beer cans. During an unrelated conversation, however, Mr. Martin mentioned to me that he switched to selling beer in cans rather than bottles at the request of the local sheriff. Apparently the sheriff had received complaints about glass on the road from motorists. Although Mr. Martin did not provide a date for this switch, the abundance of "pop-top" open cans is a fairly strong indication that it took place in the 1970s. The largest artifact fragments were found near the outhouse. These included some sizable chunks of ceramics, including a large base from a hollow vessel. While privies can be an unparalleled source of data for archaeologists, this one was used as recently as one decade ago, and thus is not yet ready for archaeological investigation (by me at any rate!).

Primary trash disposal, according to Mr. Martin, was across the road, where trash was burned. Unfortunately for our archaeological curiosity, this area has been under sugar-cane cultivation for some time. While artifacts recovered around and under the store were not as abundant as what I have encountered on contemporaneous residential sites, they are present in sufficient quantity, and in contexts with enough integrity, to make interpretation possible. The history and significance of Medric Martin's store in the local economy and culture merits its being recorded as a site and investigated further, particularly if it becomes threatened by development.

Inspired by Diana Greenlee's successful "screen-a-thon" event at Poverty Point, I held two "artifact wash-a-thon" events at Marksville State Historic Site this spring. Interpretive Ranger Don Fontenot made the local arrangements and he and Interpretive Ranger Judy Anderson helped with the events. Approximately 30 people participated. The events included a slide presentation on the archaeological response to Hurricane Gustav damage at Marksville, an overview of artifact processing methods, artifact washing, and, for the Tioga High School Archaeology Club, a walking tour of some of the damaged areas.

All of the participants enjoyed the opportunity to help with archaeological research and to see and touch ceramics and stone tools from more than millennia ago. Nancy Affeltranger deserves special mention for her successful efforts to bring the Tioga High School Archaeology Club to Marksville for the second wash-a-thon.



Scenes of archaeology from the Southwest Region: A) Sherry Wagener, Stacie Palmer, the LaTour family and others at the Marks-ville wash-a-thon, B) Jim Delahoussaye and Megan Garrett shovel testing at the Medric Martin's store site, C) Don Fontenot and the Tioga High School Archaeology Club at the Marksville site, D) La-Tour family members participating in the wash-a-thon, E) Don Fontenot checks his camera while Tioga HS Archaeology Club members wash artifacts.

Poverty Point Update
Dr. Diana M. Greenlee
Poverty Point Station Archaeologist
University of Louisiana – Monroe

VOLUNTEER ACTIVITIES

Wind thrown trees pose a site management problem at Poverty Point. In addition to mixing the archaeological deposits, they provide burrowing opportunities for armadillos and the exposed surfaces are subject to erosion. Our goals are to document the disturbance, to remove the root ball and trunk, and to create a stable surface that will re-vegetate. To accomplish this, we clean any loose dirt out of the root hole, map the hole and line it with landscaping fabric, knock the dirt off the root ball onto the landscaping fabric so the roots and trunk can be removed, replace the earlier removed loose dirt, and then finish filling the hole with sterile dirt, as needed.

Last summer, a large root ball (Figure 1) was brought up on Ridge 5 West. Station Archaeology Program staff cleaned, mapped and lined the root hole; some dirt was knocked off the root ball. On Saturday, 21 November 2008, five volunteers assisted with further cleaning of the root ball and most of the dirt was removed that day (Figure 2). Artifacts in the disturbed dirt included PPOs, flakes, blades, cores, steatite sherds, and a plummet. Later, the remainder of the dirt was knocked off and State Parks staff was able to remove the roots and trunk. More root balls and volunteer opportunities await!

REMOTE SENSING

Drs. Mike Hargrave and Berle Clay expanded their magnetic gradiometry survey of the plaza in the area east of Highway 577 and south of the visitor's center in September, 2008. More large circular magnetic anomalies, similar to those documented last April, were identified. Dr. Rinita Dalan will examine a sample of these new circles using coring and downhole magnetic susceptibility in May to learn more about these anomalies and how deeply they are buried. Hargrave and Clay anticipate completing their survey of the plaza and innermost ridge in 2009.

SUMMER FIELDWORK

A joint University of Louisiana - Monroe and Mississippi State University field school is planned to "ground truth" the large circular magnetic anomalies documented by Drs. Hargrave and Clay in the plaza at Poverty Point. We have selected four anomalies with different attributes for study. One to three 1 x 1 m units will be excavated into each of these anomalies to better characterize any features that may be associated with them and to acquire samples for dating. We will be working Wed-Sun from 3 June – 2 July 2009. Plan on dropping by for a visit to see what we're learning about these very intriguing anomalies!

Anybody interested in volunteer opportunities with the Poverty Point Station Archaeology Program should contact Diana (phone 318-926-3314; email greenlee@ulm.edu or povpoint@hughes.net).



Official Business

Governor Bobby Jindal Announces Appointments to the Louisiana Archaeological Survey and Antiquities Commission

BATON ROUGE – April 22, 2009, Governor Bobby Jindal announced appointments to the Louisiana Archaeological Survey and Antiquities Commission.

The Louisiana Archaeological Survey and Antiquities Commission serves to promote the goals and objectives of the Department of Culture, Recreation and Tourism and advise the department on matters relating to antiquities, archaeology and other cultural resources.

According to statute, the commission is comprised of eleven members, including the state archaeologist and one representative each from the Department of Culture, Recreation and Tourism, the Department of Natural Resources and the Governor's Office of Indian Affairs serving as ex-officio members. The remaining seven members are gubernatorial appointments, subject to senate confirmation. Each member appointed by the governor is selected from nominations submitted by the ex-officio members of the commission and must be a lay or professional archaeologist. Additionally, one appointment must be a member of the Louisiana Archaeological Society.

Appointments to the Louisiana Archaeological Survey and Antiquities Commission:

Greg Ducote, of Baton Rouge, is the administrator of the Interagency Affairs Section of the Coastal Management Division within the Louisiana Department of Natural Resources. Ducote was reappointed to serve as a representative of the Department of Natural Resources, as required by statute.

Mark Ford, of Baton Rouge, is the executive director of the Governor's Office of Indian Affairs. Ford was reappointed to serve as a representative of the Governor's Office of Indian Affairs, as required by statute.

Scott Hutcheson, of Baton Rouge, is the assistant secretary of the Office of Cultural Development within the Department of Culture, Recreation and Tourism. Hutcheson was reappointed to serve as a representative from the Department of Culture, Recreation and Tourism, as required by statute.

Dr. Jack Irion, of Kenner, is a marine archaeologist and the supervisor of the Social Sciences Unit at the Mineral Management Service within the United States Department of

the Interior. Irion was nominated to serve by the ex-officio members of the commission, as required by statute.

Dr. Charles "Chip" McGimsey, of Baton Rouge, is the state archaeologist and director of the Louisiana Division of Archaeology. McGimsey will serve as an ex-officio member, as required by statute.

Dr. Heather McKillop, of Baton Rouge, is the William G. Haag Professor of Archaeology at Louisiana State University and a member of the Archaeological Institute of America. McKillop was nominated for reappointment by the ex-officio members of the commission, as required by statute.

Dr. Nina Muller-Schwarze, of New Orleans, is a visiting assistant professor at Nicholls State University and a member of the American Anthropological Association. Muller-Schwarze was nominated by the ex-officio members of the commission, as required by statute.

Stanley Nelson, of Clayton, is the editor of the Concordia Sentinel and author of a weekly column on history in Louisiana. Nelson was nominated by the ex-officio members of the commission, as required by statute.

Dr. Mark Rees, of Lafayette, is an associate professor at the University of Louisiana at Lafayette and a member of the Louisiana Archaeology Society. Rees was nominated for reappointment by the ex-officio members of the commission to serve as a representative of the Louisiana Archaeology Society, as required by statute.

Dr. George Riser, Jr., of Covington, is a veteran of the United States Army and a retired physician. Riser was nominated for reappointment by the ex-officio members of the commission, as required by statute.

Lt. Col. Michael Tarpley of Grant Parish, recently retired from the Louisiana National Guard, has been re-named to the Commission. Col. Tarpley was nominated by the ex-officio members of the commission, as required by statute.

The Louisiana Archaeological Survey and Antiquities Commission (LASAC) Meeting

The Louisiana Archaeological Survey and Antiquities Commission met on Tuesday, March 10, 2009, at 1:30 p.m. in the Capitol Annex Building, 1051 North Third Street, Conference Room 238A, Baton Rouge, Louisiana.

Members Present:

Mr. Gregory DuCote, Mr. Marc Dupuy, Jr., Mr. James Fogleman, Mr. Mark Ford, Dr. Heather McKillop, Dr. Mark Rees, Dr. George Riser

Members Absent:

Mr. Scott Hutcheson, Dr. Chip McGimsey, LTC Michael Tarpley

Others Present:

Ms. Jill Andrew, Mr. Ray Berthelot, Ms. Kellye Cummings, Ms. Lucinda Freeman, Dr. Diana Greenlee, Ms. Nancy Hawkins, Mr. Brian Hess, Mr. Dennis Jones, Ms. Amy Mann, Dr. Rob Mann, Dr. David Palmer, Ms. Stacie Palmer, Ms. Karen Richardson, Mr. Duke Rivet, Mr. Daniel Stoute, Ms. Sherry Wagener, Ms. Cheraki Williams

Welcome & Introductions

Dr. Heather McKillop called the meeting to order at 1:30 p.m. Mr. Scott Hutcheson, Dr. Chip McGimsey, and LTC Michael Tarpley were unable to attend the meeting.

The first order of business was the approval of the minutes from the Commission Meeting held December 9, 2008.

MOTION: *A motion was made by Dr. George Riser and seconded by Mr. Gregory DuCote, to accept the minutes of the December 9, 2008, Antiquities Commission Meeting as written. The motion carried unanimously.*

Old Business

Mardi Gras Shipwreck Update

Ms. Sherry Wagener reported to the Commission on the Mardi Gras Shipwreck, an early nineteenth century shipwreck site discovered in the Gulf of Mexico off the Louisiana coast in 2002. An oilfield inspection crew for the Okeanos Gas Gathering Company found the site while surveying the proposed route of the Mardi Gras Transmission System. The Louisiana Division of Archaeology has accepted eleven boxes of artifacts from the shipwreck from the Texas A&M Conservation Research Laboratory.

Additional artifacts will arrive after they have been conserved. A press conference was held by the Department of Culture, Recreation and Tourism and Minerals Management Service in New Orleans at the Cabildo on March 8, 2009, and New Orleans television station WWL aired coverage of the event on their 6:00 pm broadcast. The New Orleans Times Picayune reported the story on the front page of the newspaper. The Office of State Museum believes that they have determined the identity of the ship, although it has yet to be confirmed. It is known that a ship named the *Rapid* went down in the Gulf of Mexico in November of 1813 while being chased by a British warship during the War of 1812, and the Mardi Gras Shipwreck site may be the remains of that vessel. The Office of State Museum will display the artifacts at the Cabildo in their War of 1812 exhibit. Additional information on the Mardi Gras Shipwreck site can be obtained through links on the Division of Archaeology website, <http://www.crt.state.la.us/archaeology/>.

New Business

Curation Facility Update

As previously reported to the Commission, the Division of Archaeology curation facility has experienced ongoing flooding and mold problems after heavy rains. Ms. Sherry Wagener stated that the Office of State Buildings had proposed a new location for the facility on the second floor of the Department of Public Safety Building. The proposed site would increase the size of the curation facility by 50% allowing for a four to five year period of growth before a larger facility would be needed. The space would be renovated to comply with federal regulations regarding the curation of archaeological collections, and it is estimated that it would be ready for occupancy in the fall of 2009.

Update-Southwestern Regional Archaeologist

Dr. David Palmer reported to the Commission on the activities from the previous grant year. Ms. Patricia Duncan with the Division of Historic Preservation and Dr. Palmer compiled the nomination to the National Register of Historic Places for the New Iberia Shipwreck Site (16IB80). The site was brought to the attention of the Division of Archaeology by Mr. Paul Allain, a resident of New Iberia. It contains the remains of a nineteenth century, flat bottom, side-wheel steamboat. This particular type of vessel was commonly used

LASAC Meeting (continued)

to transport goods along the bayous and waterways throughout the state. The site nomination was approved by the state and national committees.

Dr. Palmer provided technical assistance to the Office of State Parks by monitoring two projects at the Marksville State Historic Site. One project was the extension of a waterline and the other an addition to an existing work shed. They both involved ground disturbing activities; however, no cultural resources were impacted by either project. He also monitored geotechnical coring at Ft. DeRussy which was done to determine soil stability in advance preparation for construction of a new visitor center. The cores were up to fifteen feet deep in some areas. No cultural resources were encountered.

Then, he discussed the excavation of a new site, Bellow's Patio Discovery Site (16AC56), which was discovered by the property owners while working on a patio expansion for their home. The site contained three grave markers, cast concrete foot markers, and cast concrete post bases. No other features or human remains were found. The property owners will attempt to locate descendants of the individuals whose names are on the markers to return the artifacts to them.

Another new site that he recorded was the Wooden Shrimp Trawler Wreck Site (16LY121) that was brought to Dr. Palmer's attention by Dr. Ray Brassieur of the University of Louisiana at Lafayette over concerns that the site would possibly be destroyed. It is located on the Vermilion River and considered a hazard for boaters in the area. The trawler is a south Lafourche, shallow vessel from the mid-twentieth century.

Dr. Palmer and Dr. Chip McGimsey along with Mr. Joe and Logan Toups reinvestigated several sites along the Calcasieu River. Two shell midden sites, (16CU5) and (16CU119) had been destroyed through wave wash and erosion while other sites that were visited remained intact.

The Old Well Site (16IB50) located on Avery Island was originally recorded as a nineteenth century feature; however, Dr. Palmer learned from Mr. Clarence "Beb" Barrilleaux, a lifelong resident of the island, that the feature was constructed between 1944 and 1949. It may have been built using salvaged bricks from the Hayes Sugar House which would account for the discrepancy in the original dating of the feature. Additionally, he

provided technical assistance at the Hayes Sugar House field school conducted at Avery Island by Dr. Mark Rees of the University of Louisiana at Lafayette.

***MOTION:** A motion was made by Mr. James Fogleman and seconded by Dr. George Riser, to issue a permit for the University of Louisiana at Monroe and Mississippi State University to conduct a joint field school at Poverty Point State Historic Site. The motion carried unanimously.*

Washington University/Murray State University Field School at Poverty Point Permit Request

Ms. Nancy Hawkins presented a proposal for a permit request for a six-week Washington University/Murray State University field school at Poverty Point State Historic Site to be held in the summer of 2009. Dr. Tony Ortmann and Dr. T. R. Kidder propose to conduct archaeological work in three areas of Mound C to determine when the mound was constructed, how long this process was underway, and to refine current chronological models for the development of Poverty Point. The excavation of Mound C would also provide an opportunity to conduct detailed analysis of stratified activity surfaces to determine how the mound was used and how its function may have changed over time. The proposed work is

- to conduct a limited ground penetrating radar study
- to place one or two new 1 x 1 m units in the western toe of the mound, where the edge of the mound intersects with the plaza
- to open several units in the top of the mound, including
 - reopening Dr. Gibson's nine 1 x 1 m units from 1983
 - reopening one of Dr. Ortmann's 1 x 1 m units from 2001
 - excavating two to four new 1 x 1 m units between the reopened units, excavating them to the depth of the first activity surface
- to pull 20 2-inch solid cores from around the edge of Mound C

The researchers will work with the Office of State Parks to maximize opportunities for the public to observe archaeology in progress and to provide information to the media.

LASAC Meeting (continued)

MOTION: *A motion was made by Dr. Mark Rees and seconded by Dr. George Riser, to issue a permit for Washington University and Murray State University to conduct a joint field school at Poverty Point State Historic Site and for the permit to note that 1/8" mesh water screening will be used for soil from the new excavation units and that State procedures with regards to discoveries of human remains will be followed. The motion carried unanimously.*

University of Mississippi at Mansfield State Historic Site Permit Request

Ms. Sherry Wagener presented the proposal to conduct geophysical surveys and test excavations in search of battlefield burials on a portion of the Mansfield State Historic Site for the Center for Archaeological Research, University of Mississippi. Ground-penetrating radar (GPR), gradiometer, and electromagnetic instruments would be used to locate burial pit boundaries and test excavations would be done to confirm their findings. The Office of State Parks wants to know the exact location of the burials in order to protect them from future disturbances.

MOTION: *A motion was made by Dr. George Riser and seconded by Mr. Mark Ford, to issue a permit to conduct geophysical surveys and test excavations in search of battlefield burials on a portion of the Mansfield State Historic Site for the Center for Archaeological Research, University of Mississippi. The motion carried unanimously.*

Los Adaes/Ft. Jesup-National Park Service Workshop Permit Request

Ms. Nancy Hawkins presented a proposal for a permit for the National Park Service workshop to be held in May of 2009 at Los Adaes State Historic Site and Ft. Jesup State Historic Site. The workshop is designed to provide a practical application of geophysical equipment and aerial photographic techniques available for identification, evaluation, and the conservation and protection of cultural resources. The workshop will also serve as a platform for the introduction of new geophysical software currently under development (ArchaeoMapper).

MOTION: *A motion was made by Mr. Gregory DuCote and seconded by Mr. James Fogleman, to issue a permit to the National Park Service workshop at Los Adaes State Historic Site and Ft. Jesup State Historic Site. The motion carried unanimously.*

Louisiana State University-Port Hudson State Historic Site Permit Request

Dr. Rob Mann, Southeast Regional Archaeologist, introduced Mr. Brian Hess, master's candidate in the Department of Geography and Anthropology at LSU. Mr. Hess presented a proposal for a permit to investigate Civil War earthworks at Port Hudson State Historic Site (16EF7). The purpose of the investigation is to generate data that will assist the park with interpretation of the events of the Siege of Port Hudson and provide data for a master's thesis for Mr. Hess. The project will focus on locating the Union sap trench near Ft. Desperate and analysis of the trench fill.

MOTION: *A motion was made by Dr. Mark Rees and seconded by Mr. Gregory DuCote, to issue a permit to conduct field investigations at Port Hudson State Historic Site. The motion carried unanimously.*

Other Business

Dr. Rees stated that the Commission still has a vacancy. He suggested Ms. Kimberly Walden, the cultural director for the Chitimacha Tribe of Louisiana, as a possible nominee to fill the position.

Dr. McKillop reminded the Commission that the current members need to be reappointed by the new governor and that they should forward all required information to Dr. Chip McGimsey. Then, she announced that the Department of Geography and Anthropology had interviewed Dr. Shannon Dawdy for a tenured position at LSU.

Mr. Mark Ford, director of the Louisiana Governor's Office of Indian Affairs, announced that three tribes in the state were applying for State and Federal recognition, the Atakapa Ishak, Avoyel Tensas, and Talimali Band of Apalachee.

There being no further questions, comments, or other business to bring before the Commission, Dr. McKillop entertained a motion to adjourn.

MOTION: *A motion to adjourn was made by Dr. George Riser and seconded by Mr. James Fogleman. The motion carried unanimously and the meeting adjourned at 4:30 p.m.*

**LAS Executive Committee
Kisatchie National Forest, Supervisors Office
Pineville, Louisiana
Saturday, January 10, 2009**

Attendees: Rachel Watson, George Riser, Dennis Jones, Chip McGimsey, Jackie Edwards, Nancy Affeltranger, Velicia Bergstrom, Jim Fogelman, and Agnes Fogelman.

Meeting called to order 12:35 pm.

Minutes: Chip McGimsey made a motion to approve the minutes and Velicia Bergstrom seconded the motion. The motion passed unanimously.

Officer Reports

President: George Riser resigned as President for personal reasons.

Vice President: Velicia Bergstrom is now President of LAS. She has sent notifications to Louisiana universities concerning the student paper competitions for the LAS/MAA joint annual meeting.

Secretary: No report.

Treasurer: Jim Fogelman has taken over as Treasurer. The Account balance is \$10,992.91 and the membership count is 208.

Webmaster: Hits average 98 per day. The two online newsletters are being downloaded a total of 25 times per week. We still have plenty of spare bandwidth for future growth.

Newsletter Editor: Newsletter will be mailed in mid-January.

Bulletin Editor: Chip McGimsey announced that he does not have time to continue editing the Bulletin alone. He will ask for help producing the Bulletin at the LAS Business Meeting.

Chapter Reports

Baton Rouge Chapter: Christmas Party was held at Chelsea's in Baton Rouge. Chapter meets last Wednesday of every month.

Central Louisiana Archaeology Chapter: Recently held elections. Meetings held on the second Thursday of every month. Officers are Nancy Affeltranger – President
Tommy Delerie – Vice President
Lille Jeansonne – Secretary
Charles Affeltranger – Treasurer
Jackie Edwards – Chapter Representative

Old Business

Denis Jones made a motion to reimburse one individual for travel expenses incurred during Archaeology Month. The cost is \$60. Chip McGimsey seconded the motion. The motion passed unanimously.

New Business

Shannon Dawdy has nominated Betty Pendley for the Saucier Award. George Riser made a motion to approve the nomination for award. Jim Fogelman seconded the motion. The motion passed unanimously.
The executive committee needs nominations for a new LAS Vice-President.

Announcements

The pre-registration form for the LAS/MAA joint meeting will be in the December newsletter. Note LAS on your registration check. Registration is \$15 dollars. There are 37 spaces available for papers, 17 for papers focusing on Louisiana archaeology. Paper deadline is February 13, 2009.

Professional Archaeologist of Louisiana (PAL) will meet at the joint LAS/MAA meeting. Time TBA. The organization hopes to make a presentation at the LAS Business Meeting.

Future LAS Executive Committee Dates
February 27, 2009, Natchez
June 13, 2009, Baton Rouge
September 12, 2009, Pineville
December 15, 2009, TBA

Chip McGimsey made a motion to adjourn and Jim Fogelman seconded. The motion passed unanimously.

Meetings, Fieldwork, Exhibits, Websites, Etc.

Sept. 30-Oct 4, 2009. Annual meeting of the American Society for Ethnohistory (ASE) at Hotel Monteleone, New Orleans, LA.

The theme of the meeting will be “Bridging the Gulf: Connecting the Ethnohistories of the Americas”.

This year’s conference theme builds on the history of New Orleans as a nexus between North America, the Caribbean, Central America, and South America. Just as New Orleans has combined these worlds into a cross-cultural city, this year’s meeting focuses on the ethnohistorical ties throughout the Americas and seeks to bring these seemingly distinct scholarly worlds together in collaborative fashion. We encourage panel and paper proposals that combine work being done in more than one geographical area and/or that seek to draw comparisons between ethnohistorical research and methodology developed in diverse American settings, although any panel or paper on an ethnohistorical topic will be considered.

The Louisiana Archaeological Society (LAS) will be co-sponsoring this event and all members are urged to attend. More information about the meeting and the ASE can be found at: <http://ethnohistory.org>.

Southeastern Archaeological Conference (SEAC) 66th Annual Meeting!!! November 4-7, 2009, Renaissance Riverview Hotel – Mobile, Alabama

The newly renovated Renaissance Riverview Hotel is located in the revitalized Mobile downtown entertainment district. Rising majestically over the sparkling waters of Mobile Bay and located just off of I-10, near the I-65 and I-10 connection. The room rate is \$124 plus tax (ca. 14% currently) or a Bayview Parlor from \$189 plus tax. Deadline for the submission of papers, posters, symposia, and special events is August 21, 2009. For more information go to www.southeasternarchaeology.org/ and click on Annual Meeting.

Zilker Park Excavations-Austin, Texas

Located at the confluence of the Colorado River and Barton Creek, the area today known as Zilker Park in Austin has been attracting people for millennia. Recent research has demonstrated that much of Zilker Park encompasses a massive archeological site, known as the Vara Daniel Site, with buried deposits that represent more than 10,000 years of history and prehistory. Prehistoric Native Americans came here to camp, hunt, fish, forage, and like modern people, bathe in the waters of Barton Springs. In April of 2009 the City of Austin will sponsor an excavation focusing on the oldest deposits associated with this site. These archeological deposits are buried more than ten feet below the current ground surface and represent what archaeologists term the Paleoindian period, which lasted from about 11,500 years B.C. to about 8,200 B.C. Frequently updated information about this project can be found online at <http://archeologyatzilker.com/>

ARKANSAS ARCHEOLOGICAL TRAINING PROGRAM

June 13 - 28, 2009, Carden Bottom, Winthrop Rockefeller Institute, Morrilton, AR.

The excavations this year will be at Carden Bottom site (3YE347) at the foot of Petit Jean Mountain. Headquarters, seminars, field laboratory, group camping area, and evening programs will be at Winthrop Rockefeller Institute on top of Petit Jean Mountain. Specific details about research plans, excavation techniques, and daily schedule will be sent in a packet to those who register. More information is available at the website for the Arkansas Archaeological Society: <http://www.arkarch.org/>

LAS MEMBERSHIP APPLICATION AND DUES RENEWAL

Regular Membership	Annually \$20.00
Associate Membership	Annually \$5.00
Life Membership	\$200.00
Sustaining Membership	\$300.00
Student Membership	Annually \$12.00
Libraries & Institutions	Annually \$20.00

PLEASE PRINT OR TYPE

Name _____

Organization (optional) _____

Address _____

City _____ State _____ Zip _____

Email Address _____

Names of Associate Members _____

All memberships are for the calendar year, January 1 through December 31. Regardless of the time of year during which you join the society, you will receive all publications for the year specified.

Back Issues of LAS Bulletins, \$15.00 each. Orders of 10 to 14 copies, \$13.50 each;

orders of 15 or more copies, \$12.75 each. Available Bulletins are:

#1(1974), #3(1976), #7(1980), #8 (1981), #9 (1982), #10 (1983), #11 (1984), #12 (1985), #13 (1986), #14 (1987), #15 (1988), #16 (1989), #17(1990), #18(1991), #19(1992), #20(1993), #21(1994), #22(1995), #23(1996), #24(1997), #25(1998), #26 (1999).

Back Issues of LAS Special Publications:

SP #1 Stone Points and Tools of Northwestern Louisiana (1981, Reprinted 2000)	\$4.00
SP #2 LAS 10th Anniversary Issue (1984)	(out of print)
SP #3 Louisiana's Archaeological Radiometric Database	\$4.00

Optional Donation: Roger T Saucier Memorial Fund \$ _____ -

Make checks payable to:
Louisiana Archaeological Society

Send payment to:
 Jim Fogleman, LAS Treasurer
 P.O. Box 118
 Morrow, LA 71355

Information for Subscribers

The Newsletter of the Louisiana Archeological Society is published three times a year for the society. Subscription is by membership in the Louisiana Archeological Society (LAS). Annual membership dues are \$20 for individuals, libraries, and institutions. \$5.00 for associates (relatives of individual members) and \$12 for students. Life membership dues are \$200 for individuals. Sustaining membership dues for individuals or institutions are \$300. In addition to the newsletter, members receive one issue per year of the bulletin Louisiana Archaeology. Membership requests, subscription dues, changes of address, and back issue orders should be directed to the Treasurer. Unless otherwise indicated, opinions stated herein are those of the Newsletter Editor and do not necessarily reflect society policy

Information for Contributors

Send all notes, news, graphics and other communication to:

Dennis Jones-LAS Newsletter Editor

Snail mail: 1801 Ormandy Dr, Baton Rouge, LA 70806

Email: archaeoman2003@yahoo.com

If possible articles should be submitted on computer disk or by email, preferably in Microsoft Word. Digital images are encouraged. Please send in JPG or Word format. Contact editor via email with all questions.

LAS Web Site

www.laarchaeology.org

LAS OFFICERS

President: Ms. Velicia Bergstrom, Pineville, LA

Vice President: Mr. Johnny Guy, Leesville, LA

Secretary: Rachel Watson, Baton Rouge, LA

Treasurer: Mr. James Fogleman, Morrow, LA

Bulletin Editor/Newsletter Editor: Dennis Jones, Baton Rouge, LA

Webmaster: Junior Doughty, Tullos, LA

All officers can be contacted through the LAS website

Louisiana Archaeological Society

P.O Box 118

Morrow, LA

71351

NEWSLETTER OF THE LOUISIANA ARCHAEOLOGICAL SOCIETY

Description	Count
Flakes	1184 (24 novaculite)
Angular fragments	217 (1 novaculite)
Bifaces and biface fragments	387 (3 novaculite, 1 indeterminate chert)
Drills	9
Adzes (polish on the bits)	2
Cores and core/hammerstones	3
Retouched pieces	15 (1 novaculite)
Early Archaic lanceolate	1
Archaic side-notched point reworked into scraper	1
Bulverde point	
Evans points	
Marcos points	
Yarbrough point	
Williams point	
Birds Creek point	
Ellis points	
Marshall points	
Little Bear Creek points	
Macon points	
Late Archaic barbed points	
Kent points	
Gary points	
Gary/Kent points	
Pontchartrain points	2
Late Archaic stemmed points	12 (2 novaculite)
Indeterminate dart points and fragments	72 (1 indeterminate chert)
Atba point	1
Indeterminate arrow points	5
Oversize cache blade (?)	1
Baytown Plain rim with lip notches	1
Marksville Stamped, var. <i>Manny</i>	1
Stone beads	9
Historic Kaolin pipe stems	2

